



Custom Service & Design, Inc.

P.O. Box 214923
AUBURN HILLS, MI 48321

PHONE: 248.340.9005
FAX: 248.340.9002

WWW.CUSTOMSERVICEANDDESIGN.COM

STRAINERS
BULLETIN: STRAINER-08-1

Why get your Strainers from CSD

- ⇒ High quality products at competitive pricing.
- ⇒ CSD has been offering a variety of strainer and other hydraulic accessory products for over 15 years.
- ⇒ Our line of NPT (National Pipe Thread) suction strainers come in a variety of sizes ranging from 1/4" to 4".

Strainers

MODEL	PIPE SIZE	FLOW (gpm)	DIAM. A (inch)	DIAM. B (inch)	WEIGHT (lbs)	LIST
FSMF-02	1/4"	2	2 1/4	2 1/4	.20	\$10.64
FSMF-03	3/8	3	2 1/4	2 1/4	.20	\$10.64
FSMF-04	1/2	5	2 1/4	4	.26	\$10.77
FSMF5-04	1/2	5	2 3/4	3	.50	\$24.03
FSMF-06	3/4	8	2 1/4	5 1/2	.32	\$14.43
FSMF5-06	3/4	8	2 3/4	3 1/4	.52	\$24.35
FSMF-08	1	10	2 3/4	5 3/4	.50	\$15.87
FSMF5-08	1	10	2 3/4	5 1/2	.70	\$28.08
FSMF-10	1 1/4	20	2 3/4	7 1/2	.62	\$24.08
FSMF5-10	1 1/4	20	3 1/4	7	1.08	\$41.01
FSMF-12	1 1/2	30	3 1/4	8	.92	\$31.07
FSMF5-12	1 1/2	30	4	9 3/4	1.74	\$45.84
FSMF-16	2	55	4	9	1.30	\$42.75
FSMF	2	55	4	10	1.78	\$73.55
FSMF-20	2 1/2	80	6 1/4	14	2.96	\$83.33
FSMF5-20	2 1/2	80	5 1/2	10	2.78	\$101.23
FSMF-24	3	120	6 1/4	14	3.10	\$83.33
FSMF5-24	3	120	5 1/2	11 3/4	3.16	\$101.23
FSMF-32	4	200	8 1/4	15	8.16	\$329.33

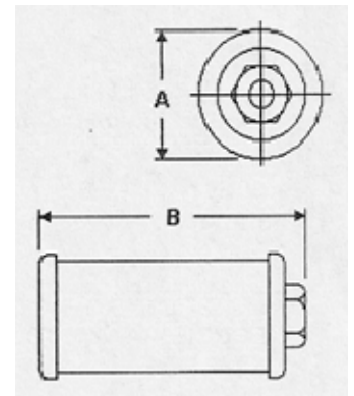

5 psi bypass valve on FSMF5 Models

